



High Performance FOV Switching Mechanism Design for an Infrared Zoom Lens

Chun-Ju Huang¹, Cheng-Shi Tsai¹, Bo-Ru Chen¹, Jia-Yush Yen^{1,*}, Jyh-Fa Lee³, Liu-Hus Lin², and Min-Shin Chen¹

¹Department of Engineering, National Taiwan University, Taiwan

²Department of Mechanical Engineering, De-Lin Institute of Technology, Taiwan

³Technical Superintendent, Materials & Electro-Optics Research Division, Chung-Shan Institute of Science & Technology, Taiwan

Received

Accepted

Published on line

Abstract:

Keywords:

1. Introduction

Optical Compensation

Mechanical Compensation

Optical compensation



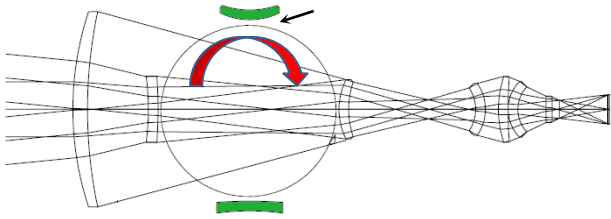

Mechanical compensation

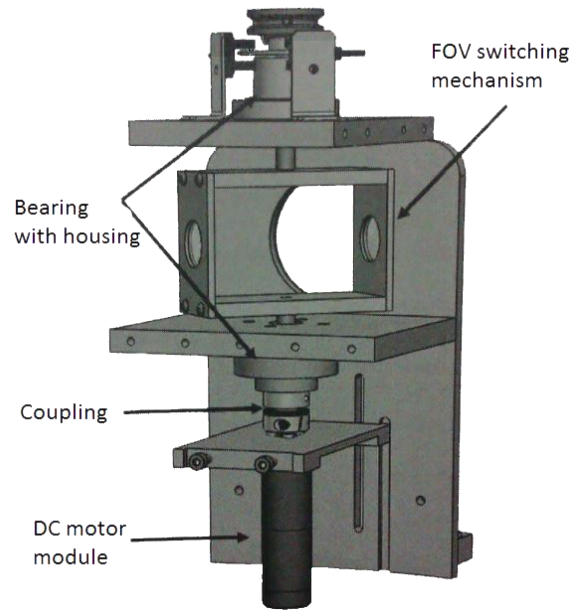

2. Design of Infrared Zoom Lens System

2.1 Design of FOV switching mechanism

Chun-Ju Huang

Cheng-Shi Tsai

Bo-Ru Chen

Jia-Yush Yen

Jyh-Fa Lee

Liu-Hus Lin

Min-Shin Chen



2.2 System identification

Sensing head
of Omron
ZX-E series

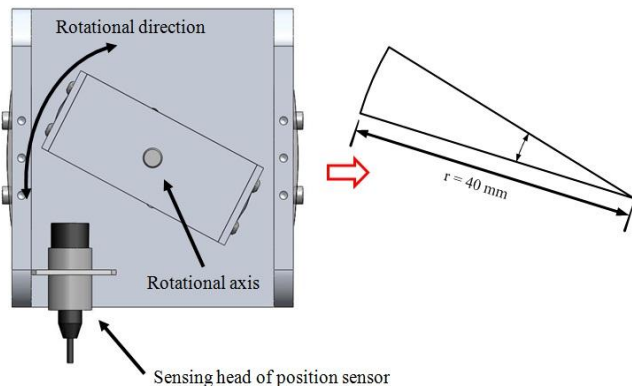
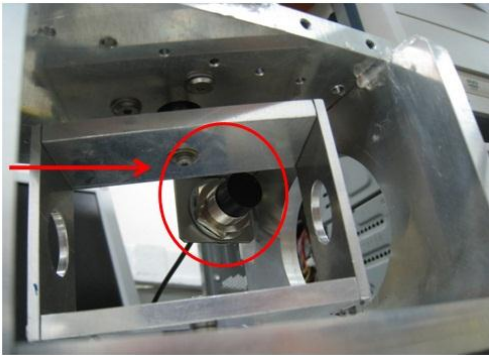

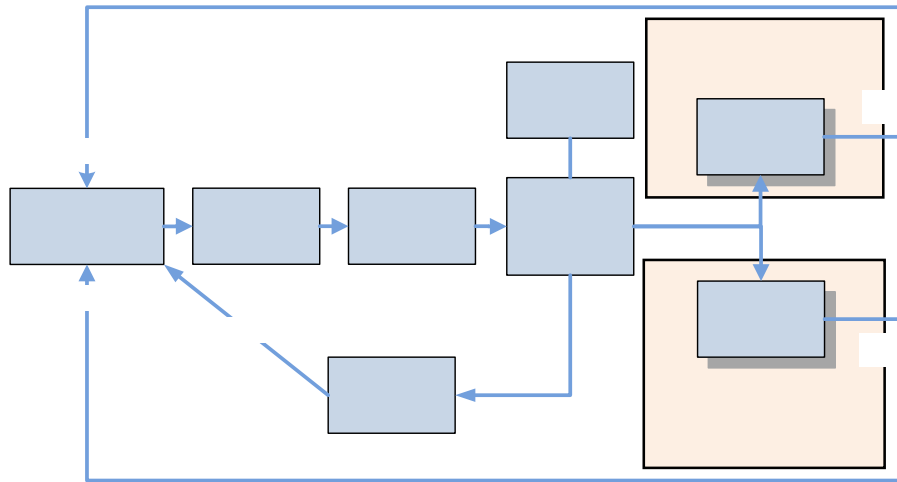
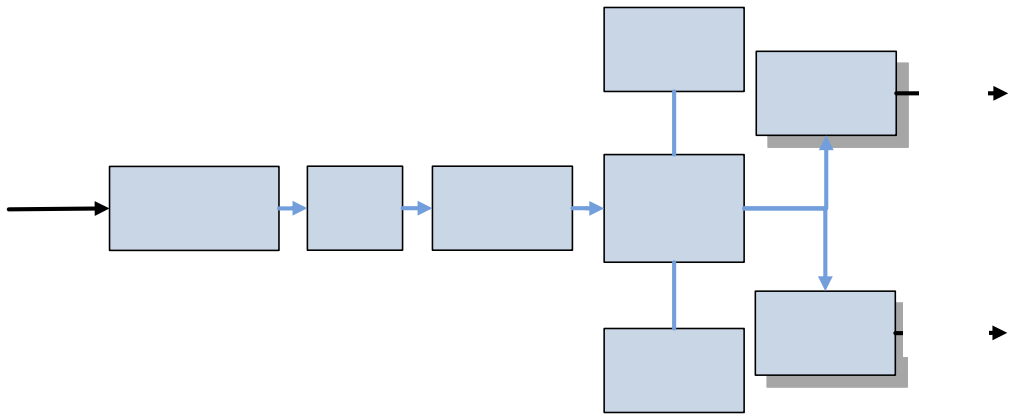

3. Controller Design

3.1 Overview of infrared zoom lens



3.2 Control strategies

4. Experimental Results

4.1 Simulink implementation setup

3.3 PID controller

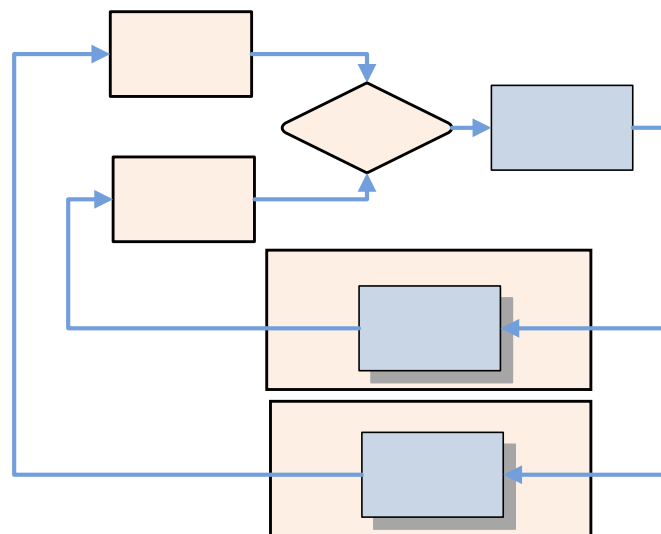

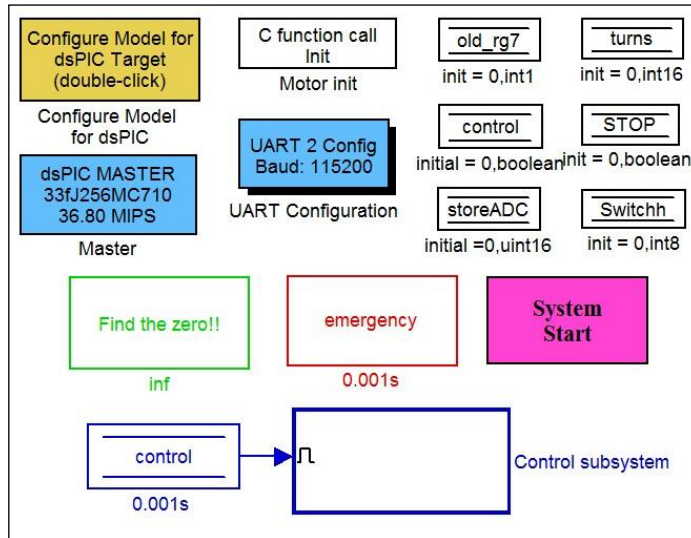

-
-
-

±

4.2 Experimental results



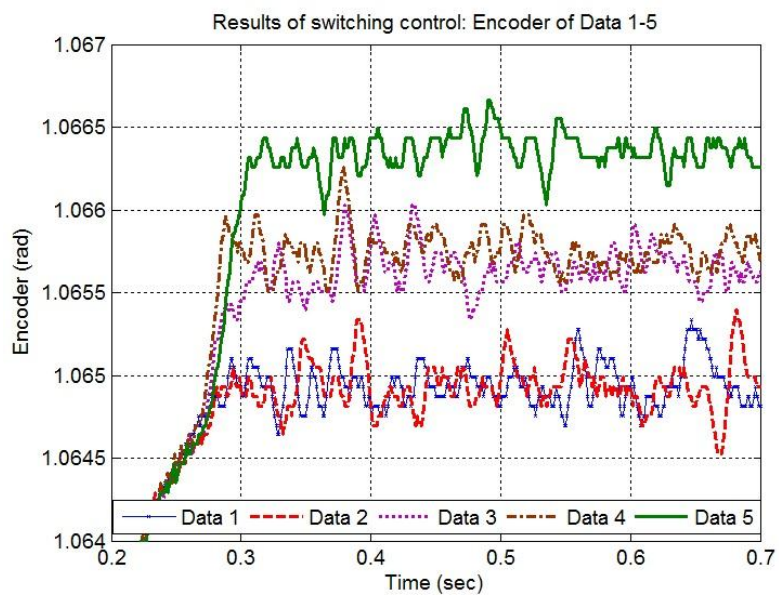
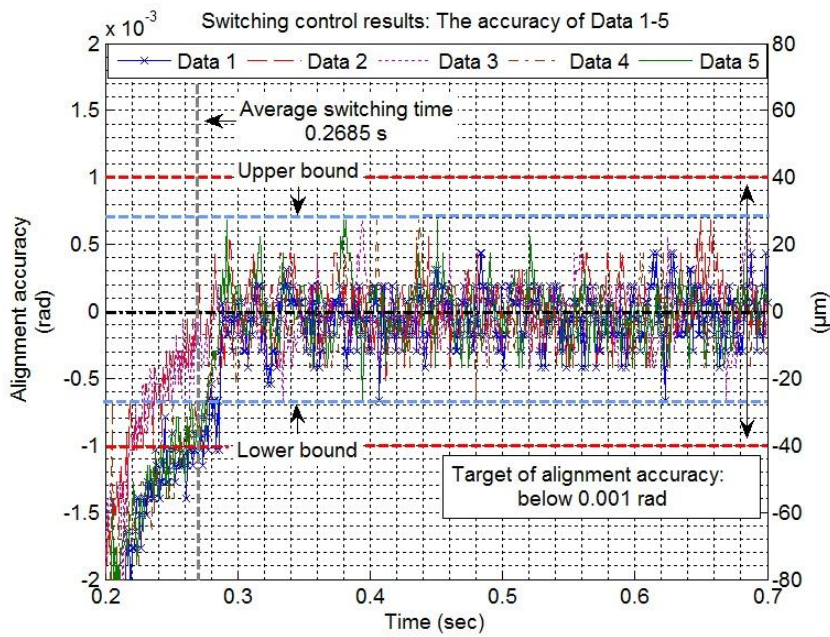

	Brake 1	Brake 2	Brake 3	Brake 4	Brake 5	Average
(mm)						
(rad)		$\times 10^{-4}$	$\times 10^{-4}$	$\times 10^{-4}$	$\times 10^{-4}$	$\times 10^{-4}$

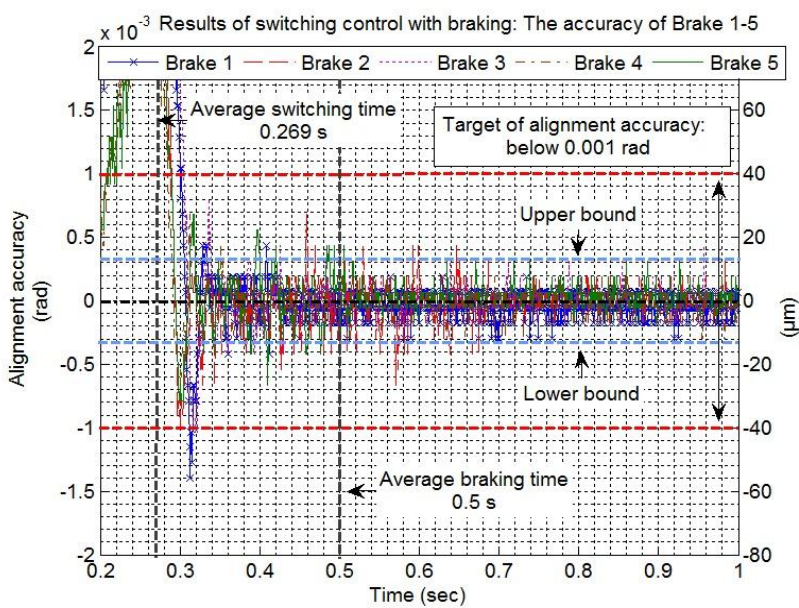
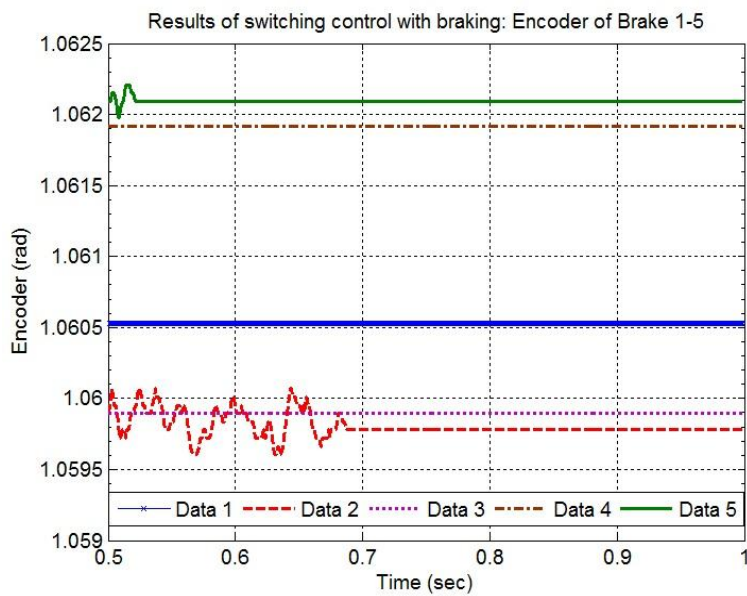

Acknowledgement

μ

References

The manual of photography
Modern optical engineering: The design of optical systems

Opto-mechanical systems design

Basic photographic materials and processes

Intermediate optical design

Journal of Optics A: Pure and Applied Optics,

Proceeding SPIE 4767

SPIE 6834

Proceeding

Industrial and Engineering Chemistry Research,

Matlab: System identification toolbox

Matlab: Response optimization 3—user's guide,

Matlab: Real-time workshop 7—user's guide,

Embedded target for dspic

5. Conclusion

